

NO. KAD PENGENALAN

							-			-				
--	--	--	--	--	--	--	---	--	--	---	--	--	--	--

ANGKA GILIRAN

--	--	--	--	--	--	--	--	--	--



**SOALAN PRAKTIS BESTARI  
PROJEK JAWAB UNTUK JAYA (JUU) 2018**



**SIJIL PELAJARAN MALAYSIA  
MATHEMATICS  
Kertas 1 (SET 1)**

**1449/1**

$1\frac{1}{4}$  jam

Satu jam lima belas minit

---

**JANGAN BUKA KERTAS SOALAN INI SEHINGGA DIBERITAHU**

1. Kertas soalan ini adalah dalam dwibahasa.
2. Soalan dalam Bahasa Inggeris mendahului soalan yang sepadan dalam Bahasa Melayu.
3. Calon dikehendaki membaca maklumat di halaman belakang kertas soalan ini.

---

Kertas soalan ini mengandungi 31 halaman bercetak dan 1 halaman tidak bercetak.

[Lihat halaman sebelah

**SULIT****MATHEMATICAL FORMULAE****RUMUS MATEMATIK**

The following formulae may be helpful in answering the questions. The symbols given are the ones commonly used.

*Rumus-rumus berikut boleh membantu anda menjawab soalan. Simbol-simbol yang diberi adalah yang biasa digunakan.*

**RELATIONS  
PERKAITAN**

$$1 \quad a^m \times a^n = a^{m+n}$$

$$2 \quad a^m \div a^n = a^{m-n}$$

$$3 \quad (a^m)^n = a^{mn}$$

$$4 \quad A^{-1} = \frac{1}{ad-bc} \begin{pmatrix} d & -b \\ -c & a \end{pmatrix}$$

$$5 \quad \text{Distance / Jarak} = \sqrt{(x_1 - x_2)^2 + (y_1 - y_2)^2}$$

$$6 \quad \text{Midpoint / Titik tengah} , (x, y) = \left( \frac{x_1 + x_2}{2}, \frac{y_1 + y_2}{2} \right)$$

$$7 \quad \text{Average speed} = \frac{\text{distance travelled}}{\text{time taken}}$$

$$\text{Purata Laju} = \frac{\text{jarak yang dilalui}}{\text{masa yang diambil}}$$

$$8 \quad \text{Mean} = \frac{\text{sum of data}}{\text{number of data}}$$

$$\text{Min} = \frac{\text{hasil tambah nilai data}}{\text{bilangan data}}$$

$$9 \quad \text{Mean} = \frac{\text{sum of (classmark} \times \text{frequency)}}{\text{sum of frequencies}}$$

$$\text{Min} = \frac{\text{hasil tambah (nilai titik tengah kelas} \times \text{kekerapan)}}{\text{hasil tambah kekerapan}}$$

$$10 \quad \text{Pythagoras Theorem / Teorem Pithagoras}$$

$$c^2 = a^2 + b^2$$

$$11 \quad P(A) = \frac{n(A)}{n(S)}$$

$$12 \quad P(A') = 1 - P(A)$$

**SULIT**

$$13 \quad m = \frac{y_2 - y_1}{x_2 - x_1}$$

$$14 \quad m = - \frac{y - \text{int ercept}}{x - \text{int ercept}}$$

$$m = - \frac{p \text{ int asan} - y}{p \text{ int asan} - x}$$

**SHAPES AND SPACE****BENTUK DAN RUANG**

$$1 \quad \text{Area of trapezium} = \frac{1}{2} \times \text{sum of parallelsides} \times \text{height}$$

$$\text{Luas trapezium} = \frac{1}{2} \times \text{hasil tambah dua sisi selari} \times \text{tinggi}$$

$$2 \quad \text{Circumference of circle} = \pi d = 2\pi r$$

$$\text{Lilitan bulatan} = \pi d = 2j$$

$$3 \quad \text{Area of circle} = \pi r^2$$

$$\text{Luas bulatan} = \pi j^2$$

$$4 \quad \text{Curved surface area of cylinder} = 2\pi rh$$

$$\text{Luas permukaan melengkung silinder} = 2\pi jt$$

$$5 \quad \text{Surface area of sphere} = 4\pi r^2$$

$$\text{Luas permukaan sfera} = 4\pi j^2$$

$$6 \quad \text{Volume of right prism} = \text{cross sectional area} \times \text{length}$$

$$\text{Isipadu prisma tegak} = \text{luas kerentas} \times \text{panjang}$$

$$7 \quad \text{Volume of cylinder} = \pi r^2 h$$

$$\text{Isipadu slinder} = \pi j^2 t$$

$$8 \quad \text{Volume of cone} = \frac{1}{3} \pi r^2 h$$

$$\text{Isipadu kon} = \frac{1}{3} \pi j^2 t$$

**SULIT**

9 Volume of sphere =  $\frac{4}{3}\pi r^3$

*Isipadu sfera* =  $\frac{4}{3}\pi j^3$

10 Volume of right pyramid =  $\frac{1}{3} \times \text{base area} \times \text{height}$

*Isipadu piramid tegak* =  $\frac{1}{3} \times \text{luas tapak} \times \text{tinggi}$

11 Sum of interior angles of a polygon

*Hasil tambah sudut pedalaman poligon*

=  $(n - 2) \times 180^\circ$

12  $\frac{\text{arc length}}{\text{circumference of circle}} = \frac{\text{angle subtended at centre}}{360^\circ}$

$\frac{\text{panjang lengkok}}{\text{lilitan bulatan}} = \frac{\text{sudut pusat}}{360^\circ}$

13  $\frac{\text{area of sector}}{\text{area of circle}} = \frac{\text{angle subtended at centre}}{360^\circ}$

$\frac{\text{luas sektor}}{\text{luas bulatan}} = \frac{\text{sudut pusat}}{360^\circ}$

14 Scale factor,  $k = \frac{PA'}{PA}$

*Faktor skala*,  $k = \frac{PA'}{PA}$

15 Area of image =  $k^2 \times \text{area of object}$

*Luas imej* =  $k^2 \times \text{luas objek}$

**SULIT**

- 1 An external hard disk has a capacity of 500 GigaByte.  
*Sebuah pemacu keras luaran mempunyai kapasiti 500 GigaByte.*

Express the capacity in byte.  
*Ungkapkan kapasiti tersebut dalam byte.*  
(1 Gigabyte =  $10^6$  kilobyte)

- A  $5 \times 10^8$
- B  $5 \times 10^9$
- C  $5 \times 10^{11}$
- D  $5 \times 10^{12}$

- 2 Express  $80 \div (0.2 \times 10^{-5})$  in standard form.  
*Ungkapkan  $80 \div (0.2 \times 10^{-5})$  dalam bentuk piawai.*

- A  $4 \times 10^{-7}$
- B  $4 \times 10^{-3}$
- C  $4 \times 10^3$
- D  $4 \times 10^7$

- 3 Express  $13_5$  as a number in base ten.  
*Ungkapkan  $13_5$  sebagai suatu nombor dalam asas sepuluh.*

- A 5
- B 8
- C 23
- D 32

**SULIT**

- 4 Given that  $x > 22$  such as  $x$  is an integer. Express the minimum value of  $x$  in base eight.  
*Diberi  $x > 22$  dengan keadaan  $x$  ialah integer. Ungkapkan nilai minimum bagi  $x$  dalam asas lapan.*

- A  $22_8$   
 B  $23_8$   
 C  $26_8$   
 D  $27_8$

- 5 Diagram 1 shows two regular pentagons PQRST and PTUVW.  
*Rajah 1 menunjukkan dua pentagon sekata PQRST dan PTUVW.*

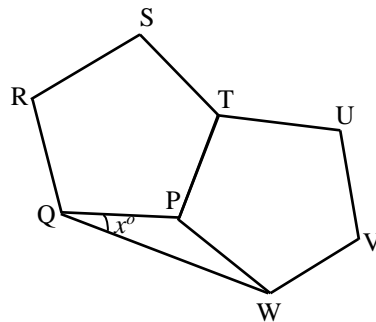

Diagram 1  
*Rajah 1*

Find the value of  $x$ .  
*Cari nilai  $x$ .*

- A 18  
 B 30  
 C 36  
 D 60

**SULIT**

- 6 In Diagram 2,  $QP$  is a tangent to the circle at point  $Q$ .  $RS$  is a diameter to the circle.  
*Dalam Rajah 2,  $QP$  ialah tangen kepada bulatan di titik  $Q$ .  $RS$  ialah diameter kepada bulatan.*

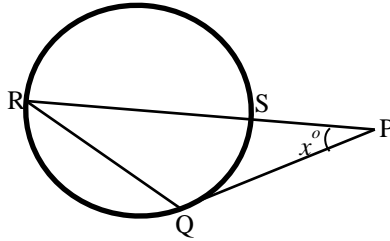

Diagram 2  
*Rajah 2*

Given that  $\angle RQP$  is  $130^\circ$ , find the value of  $x$ .  
*Diberi bahawa  $\angle RQP$  ialah  $130^\circ$ , cari nilai  $x$ .*

- A 5
- B 10
- C 25
- D 40

## SULIT

- 7 Diagram 3 shows a regular hexagon PQRSTU.  
*Rajah 3 menunjukkan sebuah heksagon sekata PQRSTU.*

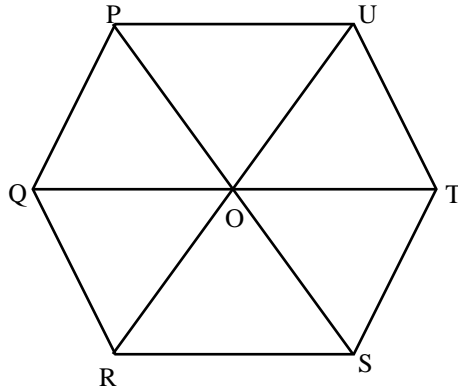

Diagram 3  
*Rajah 3*

Given that R is the image of point P under rotation at point O. Which of the following is true?

*Diberi R ialah imej bagi titik P di bawah putaran pada pusat O. Antara berikut, yang manakah benar?*

	Angle of rotation <i>Sudut putaran</i>	Direction of rotation <i>Arah putaran</i>
A	$90^\circ$	Clockwise <i>Arah ikut jam</i>
B	$120^\circ$	Anticlockwise <i>Arah lawan jam</i>
C	$240^\circ$	Anticlockwise <i>Arah lawan jam</i>
D	$270^\circ$	Clockwise <i>Arah ikut jam</i>



**SULIT**

- 8 Diagram 4 shows a pentagon drawn on a Cartesian plane.  
*Rajah 4 menunjukkan sebuah pentagon dilukis pada satah Cartes.*

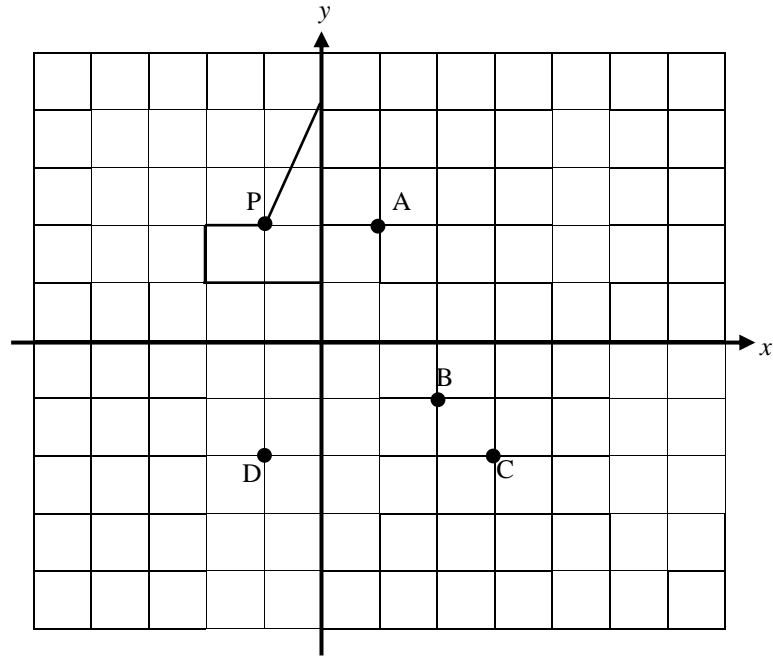

Diagram 4  
*Rajah 4*

Which of the point A,B,C or D is the image of point P under reflection in the line  $y = x$ ?

*Antara titik A, B, C dan D, yang manakah imej bagi titik P di bawah pantulan pada garis  $y = x$ ?*

SULIT

- 9 Which of the graph represents  $y = \cos x^\circ$  for  $135^\circ \leq x \leq 225^\circ$ ?  
 Graf manakah yang mewakili  $y = \cos x^\circ$  bagi  $135^\circ \leq x \leq 225^\circ$ ?

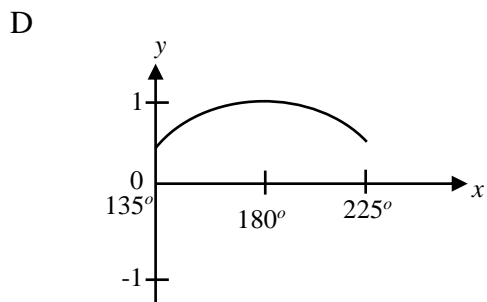
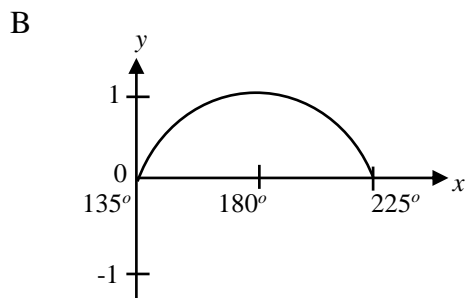
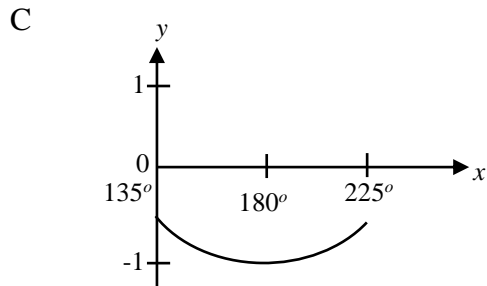
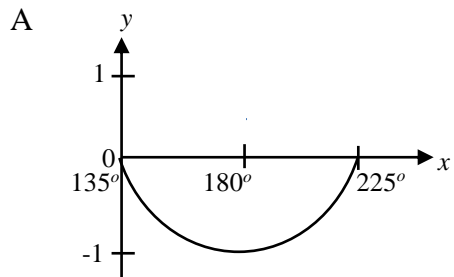

## SULIT

- 10 Diagram 5 shows two right angle triangles RQT and SUT. PQT and SVU are straight lines.

*Rajah 5 menunjukkan dua segi tiga bersudut tegak RQT dan SUT. PQT dan SVU adalah garis lurus.*

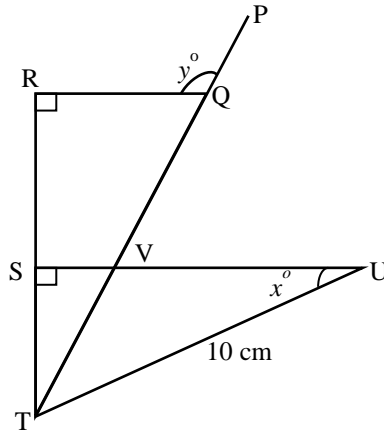

Diagram 5  
Rajah 5

Given that  $\sin x = \frac{3}{5}$  and  $VU = 3 SV$ , find  $\tan y$ .

*Diberi bahawa  $\sin x = \frac{3}{5}$  dan  $VU = 3 SV$ , cari  $\tan y$ .*

- A  $\frac{1}{6}$
- B  $\frac{1}{3}$
- C 3
- D 6

## SULIT

- 11 Diagram 6 shows a prism  $PQRSTU$  on a horizontal plane.  
*Rajah 6 menunjukkan sebuah prisma  $PQRSTU$  pada satah mengufuk.*

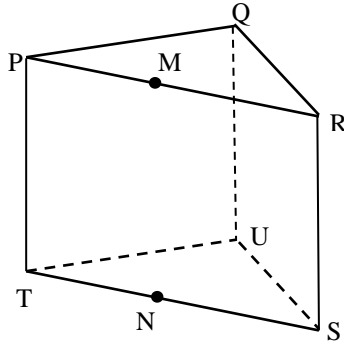

Diagram 6  
*Rajah 6*

State the angle between line  $QN$  and plane  $PRST$ .  
*Nyatakan sudut antara garis  $QN$  dan satah  $PRST$ .*

- A  $\angle SNQ$
- B  $\angle MNQ$
- C  $\angle QNU$
- D  $\angle QNP$

## SULIT

- 12 Diagram 7 shows seven points drawn on bricks arrangement on a vertical walls.  
*Rajah 7 menunjukkan tujuh titik yang dilukis pada susunan batu bata pada suatu dinding tegak.*

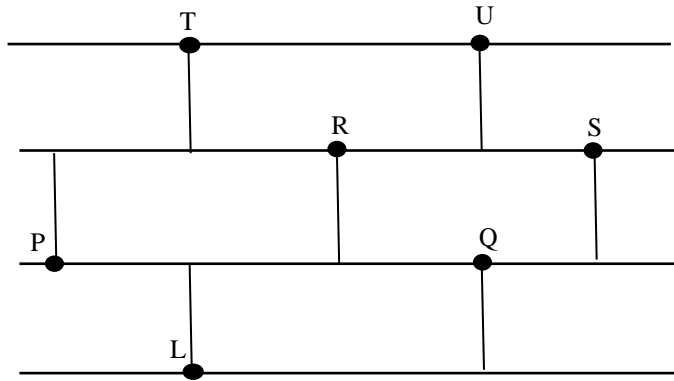

Diagram 7  
*Rajah 7*

Which of the following is **not true**?  
*Yang manakah antara berikut **tidak benar**?*

- A  $\angle RPQ$  is an angle of elevation of R from P.  
 *$\angle RPQ$  ialah sudut dongakan R dari P.*
- B  $\angle UTS$  is an angle of depression of S from T.  
 *$\angle UTS$  ialah sudut tunduk S dari T.*
- C  $\angle SRU$  is an angle of elevation of U from R.  
 *$\angle SRU$  ialah sudut dongakan U dari R.*
- D  $\angle RTL$  is an angle of depression of R from T.  
 *$\angle RTL$  ialah sudut tunduk R dari T.*

**SULIT**

- 13 Bearing Q from P is  $120^\circ$  and bearing P from R is  $020^\circ$ . Bearing Q from R is  $050^\circ$ . Which of the following represent the location of P, Q and R?  
*Bearing Q dari P ialah  $120^\circ$  dan bearing P dari R ialah  $020^\circ$ . Bearing Q dari R ialah  $050^\circ$ . Antara berikut, yang manakah mewakili kedudukan P, Q dan R?*

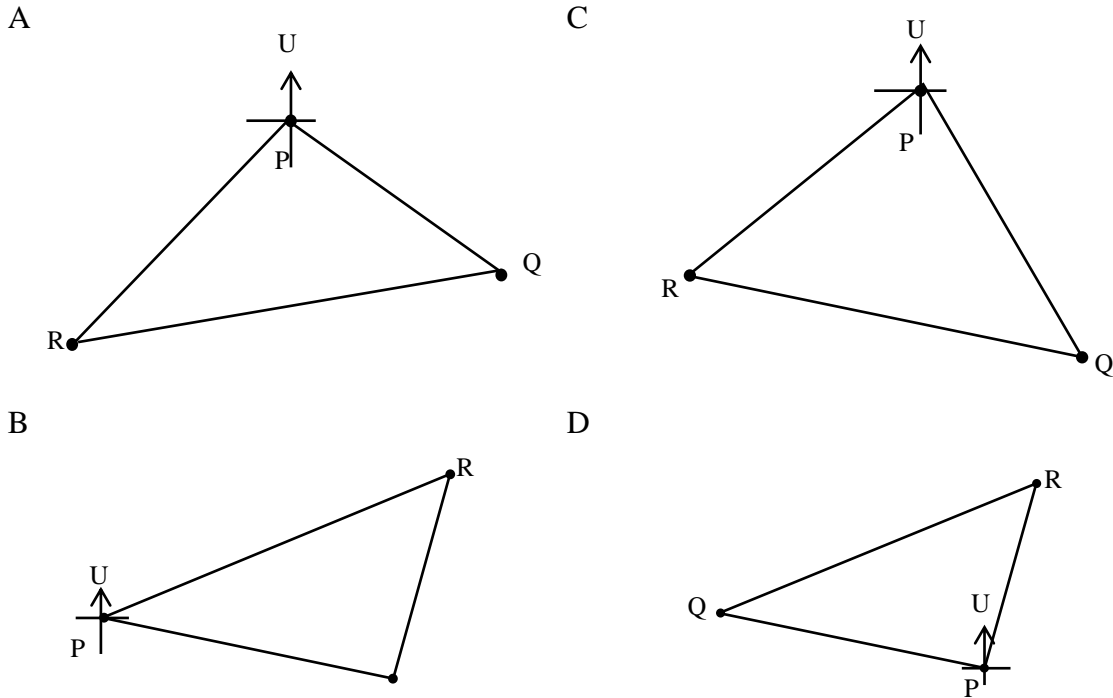

- 14 Location of point L is  $(50^\circ\text{N}, 130^\circ\text{E})$ . Point M lies due south of point L such as the difference of latitude of both points is  $20^\circ$ . Point K lies due west of point L such that the difference of longitude between both points is  $40^\circ$ . Which of the following are true?  
*Kedudukan titik L ialah  $(50^\circ\text{ U}, 130^\circ\text{ T})$ . Titik M terletak di selatan titik L dengan keadaan beza latitud antara kedua-duanya ialah  $20^\circ$ . Titik K terletak ke barat titik L dengan keadaan beza longitud antara kedua-dua titik ialah  $40^\circ$ . Antara berikut, yang manakah benar?*

	Latitude of M <i>Latitud M</i>	Longitude of K <i>Longitud K</i>
A	$30^\circ\text{N} / 30^\circ\text{U}$	$90^\circ\text{E} / 90^\circ\text{ T}$
B	$30^\circ\text{N} / 30^\circ\text{U}$	$90^\circ\text{W} / 90^\circ\text{ B}$
C	$30^\circ\text{S} / 30^\circ\text{S}$	$90^\circ\text{E} / 90^\circ\text{ T}$
D	$30^\circ\text{S} / 30^\circ\text{S}$	$90^\circ\text{W} / 90^\circ\text{ B}$

**SULIT**

15 Which of the following will produce a quadratic equation?

*Yang manakah antara berikut akan menghasilkan persamaan kuadratik?*

A  $(x - 3)(2x - 6) = 2x^2$

B  $\frac{x - 4}{3} = \frac{2}{1 - x}$

C  $x(x - 6) = x^2(1 - x)$

D  $\frac{5}{x - 1} = \frac{3}{x - 1}$

16 Given  $\frac{3}{2}\sqrt{g} + h = hk$ , express  $h$  in term of  $g$  and  $k$ .

*Diberi  $\frac{3}{2}\sqrt{g} + h = hk$ , ungkapkan  $h$  dalam sebutan  $g$  dan  $k$ .*

A  $h = \frac{2\sqrt{g}}{3(k - 1)}$

B  $h = \frac{3\sqrt{g}}{(2k - 1)}$

C  $h = \frac{3\sqrt{g}}{2(k - 1)}$

D  $h = \frac{\sqrt{g}}{2(3k - 1)}$

## SULIT

- 17 Given that  $243^{-\frac{4}{5}} = p^m$ . Which of the following is true about the value of  $p$  and  $m$ ?  
 Diberi bahawa  $243^{-\frac{4}{5}} = p^m$ . Antara berikut, yang manakah benar tentang nilai  $p$  dan  $m$ ?

	$P$	$m$
A	3	$\frac{4}{5}$
B	3	-4
C	243	-4
D	243	$\frac{4}{5}$

- 18 Diagram 8 show the price for a T-shirt, a pair of trousers and a hat.  
 Rajah 8 menunjukkan harga bagi baju-T, seluar dan topi.

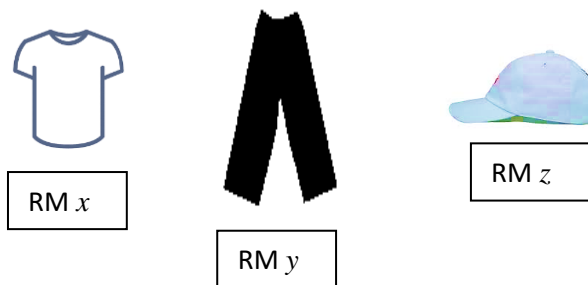

Diagram 8  
 Rajah 8

Siti has RM100. She bought 3 t-shirts, a pair of trousers and a hat. She still has a balance. State the inequality for Siti's expenses?  
 Siti mempunyai RM100. Dia membeli 3 helai baju-t, sehelai seluar dan sebiji topi. Nyatakan ketaksamaan bagi perbelanjaan Siti.

- A  $3x + y \geq 100 - z$   
 B  $3x + y > 100 - z$   
 C  $3x + y \leq 100 - z$   
 D  $3x + y < 100 - z$



## SULIT

- 19 Diagram 9 is a bar chart showing a score obtained by a group of students in a quiz.  
*Rajah 9 ialah carta bar menunjukkan skor yang diperoleh sekumpulan murid dalam suatu quiz.*

Number of students/ *Bilangan murid*

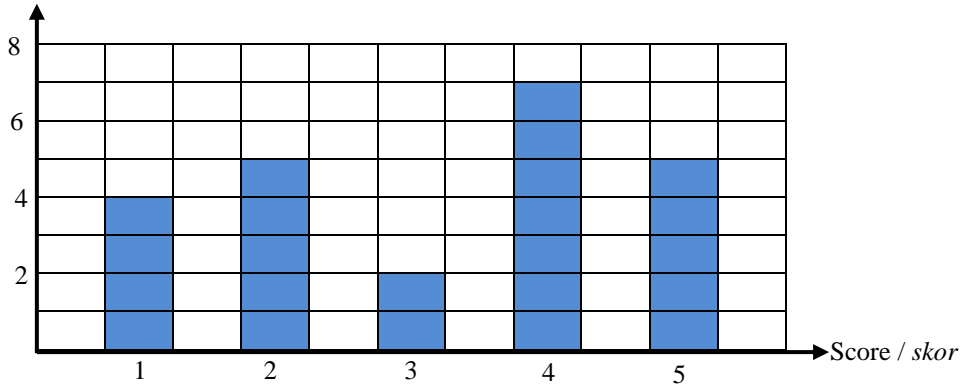

Diagram 9  
*Rajah 9*

Which of the following is true?

*Antara berikut, yang manakah benar?*

- A Score mode is 5.  
*Mod skor ialah 5.*
- B Mean is 3.17.  
*Min ialah 3.17.*
- C Total number of students is 24.  
*Jumlah bilangan pelajar ialah 24.*
- D Median is 3.  
*Median ialah 3.*
- 20 Given matrix  $Q = \begin{pmatrix} -3 & 0 & 12 \\ 7 & 14 & 5 \end{pmatrix}$ . State element of  $q_{12}$ .  
*Diberi matriks  $Q = \begin{pmatrix} -3 & 0 & 12 \\ 7 & 14 & 5 \end{pmatrix}$ . Nyatakan unsur bagi  $q_{12}$ .*
- A 0
- B 7
- C 12
- D No element / *tiada unsur*

## SULIT

- 21 Which of the following is the graph for  $y = \frac{x^2}{3}$ ?  
 Yang manakah antara berikut ialah graf bagi  $y = \frac{x^2}{3}$ ?

A

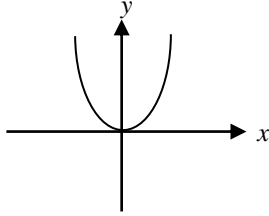

C

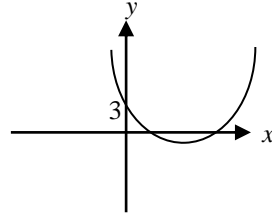

B

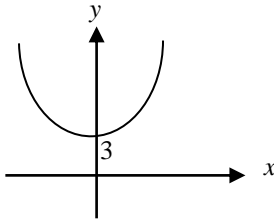

D

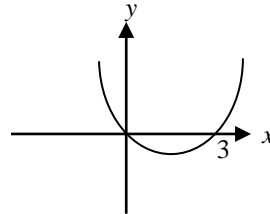

- 22 The equation of line PQ is  $3x - 2y = 6$ . Which of the following is true about the line PQ?

*Persamaan garis PQ ialah  $3x - 2y = 6$ . Antara berikut, yang manakah benar berkenaan garis PQ?*

- A The  $x$ -intercept of PQ is 3.  
*Pintasan- $x$  garis PQ ialah 3.*
- B The  $y$ -intercept of PQ is -2.  
*Pintasan- $y$  garis PQ ialah -2.*
- C The gradient of PQ is  $-\frac{3}{2}$ .  
*Kecerunan PQ ialah  $-\frac{3}{2}$ .*
- D Point (4,3) lies on line PQ.  
*Titik (4,3) terletak pada garis PQ.*

## SULIT

- 23 Diagram 10 shows a group of students consists of five boys and four girls.  
*Rajah 10 menunjukkan sekumpulan murid terdiri daripada lima murid lelaki dan empat murid perempuan.*

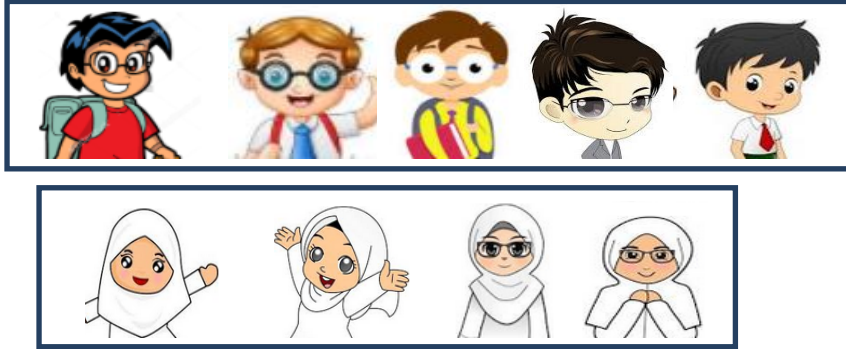

Diagram 10  
*Rajah 10*

A student is chosen at random. Which of the following is true?  
*Seorang pelajar dipilih secara rawak. Antara berikut, yang manakah adalah benar?*

- A If a student is chosen from the group, the probability of choosing a girl with spectacles is  $\frac{1}{2}$ .  
*Jika seorang murid dipilih daripada kumpulan itu, kebarangkalian memilih murid perempuan bercermin mata ialah  $\frac{1}{2}$ .*
- B If a student is chosen from the group of boy, the probability of choosing student with spectacles is  $\frac{2}{3}$ .  
*Jika seorang murid dipilih daripada kumpulan lelaki, kebarangkalian memilih murid bercermin mata ialah  $\frac{2}{3}$ .*
- C If a student is chosen from the group of student with spectacles, the probability of choosing a boy is  $\frac{2}{3}$ .  
*Jika seorang murid dipilih daripada kumpulan murid bercermin mata, kebarangkalian memilih murid lelaki ialah  $\frac{2}{3}$ .*
- D If a student is chosen from the group, the probability of choosing a boy is  $\frac{4}{9}$ .  
*Jika seorang murid dipilih dari kumpulan itu, kebarangkalian memilih murid lelaki ialah  $\frac{4}{9}$ .*

**SULIT**

- 24 Which of the following will give the answer as RM28 when round off to two significant figures?  
*Antara berikut, yang manakah akan memberi jawapan RM28 apabila dibundarkan kepada dua angka bererti?*

- A RM9.70 + RM18.90  
 B RM12.65 + RM14.75  
 C RM196.70 – RM168.20  
 D RM238.20 – RM210.30

- 25 A rectangle with length 150 mm has an area of  $150 \text{ cm}^2$ . Calculate the perimeter, in mm of the rectangle.  
*Sebuah segi empat tepat dengan panjang 150 mm mempunyai luas  $150 \text{ cm}^2$ . Hitung perimeter, dalam mm segi empat tepat tersebut.*

- A  $1.6 \times 10^2$   
 B  $2.5 \times 10^2$   
 C  $3.2 \times 10^2$   
 D  $5.0 \times 10^2$

- 26 Diagram 11 shows a rhombus TQRS. UTS and VPS are straight lines.  
*Rajah 11 menunjukkan rombus TQRS. UTS dan VPS adalah garis lurus.*

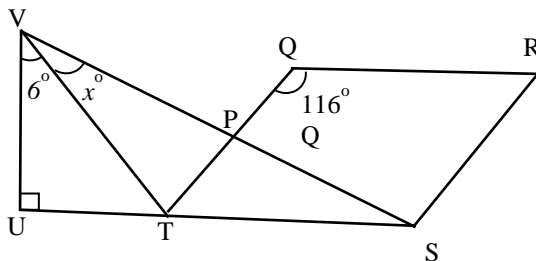

Diagram 11  
 Rajah 11

Given that  $VT = TQ$ , find the value of  $x$ .  
*Diberi  $VT = TQ$ , cari nilai  $x$ .*

- A 29  
 B 37  
 C 42  
 D 58

## SULIT

- 27 Diagram 12 shows a vertical pole. A rope with bunting flags was tied from the peak of the pole to the point P that lies on the horizontal ground.

*Rajah 12 menunjukkan sebatang tiang tegak. Seutas tali dengan bendera bunting diikat dari puncak tiang ke titik P yang terletak pada permukaan tanah mengufuk.*

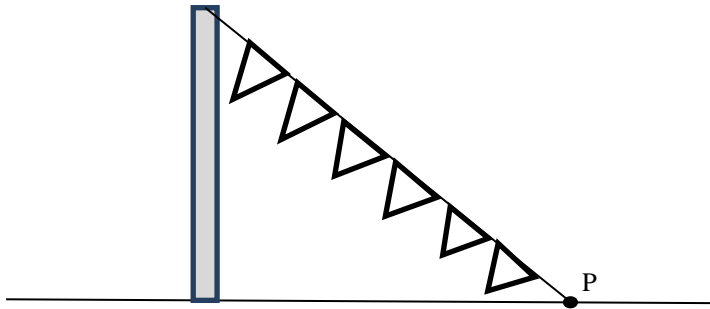

Diagram 12  
Rajah 12

Angle of depression of P from the top of the pole is  $42^\circ$  and the horizontal distance of P from the bottom of the pole is 0.8 m. Calculate the length, in m, of the rope.

*Sudut tunduk P dari puncak tiang ialah  $42^\circ$  dan jarak mengufuk P dari kaki tiang ialah 0.8 m. Hitung panjang, dalam m, tali tersebut.*

- A 0.72  
B 0.89  
C 1.08  
D 1.20
- 28 Express  $\frac{3}{mn} - \frac{2-n}{m^2n}$  as a single fraction in its simplest form.

*Ungkapkan  $\frac{3}{mn} - \frac{2-n}{m^2n}$  sebagai satu pecahan tunggal dalam bentuk termudah.*

- A  $\frac{3m - 2 + n}{m^2n}$   
B  $\frac{3m - 2 - n}{m^2n}$   
C  $\frac{3 - 2 + n}{m^2n}$   
D  $\frac{3 - 2 - n}{m^2n}$

**SULIT**

29 Given  $\frac{x}{3} - \frac{3}{4} = x + 1$ , calculate the value of  $x$ .

Diberi  $\frac{x}{3} - \frac{3}{4} = x + 1$ , hitung nilai  $x$ .

A  $-\frac{21}{8}$

B  $-\frac{5}{3}$

C  $-\frac{5}{4}$

D  $-\frac{2}{3}$

30 Simplify  $(e^{\frac{3}{2}m^3})^2 \div (e^2m^{-7})$

Permudahkan  $(e^{\frac{3}{2}m^3})^2 \div (e^2m^{-7})$

A  $e^{-\frac{1}{2}m^{-1}}$

B  $e^{-\frac{1}{2}m^{-13}}$

C  $em^{-1}$

D  $em^{13}$

31 List all the integers that satisfy the simultaneous linear inequalities

$$\frac{5}{2} - x \geq 2x + 4 \text{ and } -\frac{x}{2} - 2 \leq x + 3.$$

Senaraikan semua integer yang memuaskan ketaksaman linear serentak

$$\frac{5}{2} - x \geq 2x + 4 \text{ dan } -\frac{x}{2} - 2 \leq x + 3$$

A -2, -1

B -2, -1, 0



C -3, -2, -1

D -3, -2, -1, 0

## SULIT

- 32 Diagram 13 is an incomplete pictograph showing the number of packet of frozen curripuff sold by Puan Ani in four weeks.

*Rajah 13 ialah piktograf yang tidak lengkap menunjukkan bilangan bungkusan karipap dingin beku yang dijual oleh Puan Ani dalam empat minggu.*

Week 1 <i>Minggu 1</i>	
Week 2 <i>Minggu 2</i>	
Week 3 <i>Minggu 3</i>	
Week 4 <i>Minggu 4</i>	

 Represent 10 packets of curripuff  
*Mewakili 10 bungkusan karipap*

Diagram 13  
*Rajah 13*

The ratio of curripuff sold in first week to the curripuff sold in fourth week is 2:3. One packet of curripuff sold at RM6 and the total sale in four weeks is RM1 680. Calculate the percentage of sales in the second week.

*Nisbah jualan karipap dalam minggu pertama kepada jualan karipap minggu keempat ialah 2:3. Sebungkus karipap dijual dengan harga RM6 dan jumlah jualan dalam empat minggu ialah RM1 680. Hitung peratus jualan dalam minggu kedua.*

- A 4.76%
- B 28.57%
- C 46.43%
- D 60.71%

**SULIT**

- 33 Diagram 14 is a line graph showing pocket money received by a group of students.  
*Rajah 14 ialah graf garis menunjukkan wang saku yang diterima sekumpulan murid.*

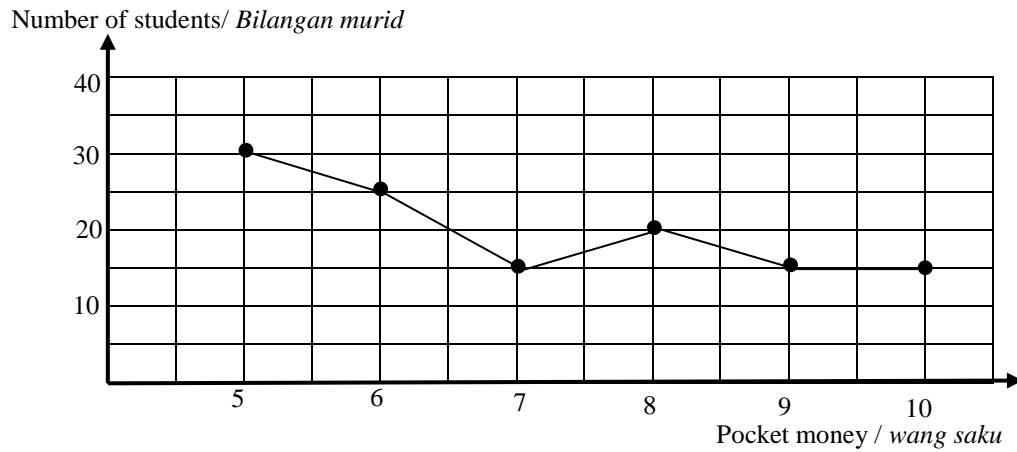

Diagram 14  
 Rajah 14

If the information is represented by pie chart, calculate the angle of sector for mode of pocket money.

*Jika maklumat tersebut diwakilkan oleh carta pai, hitung sudut sektor untuk mod wang saku.*

- A  $15^\circ$
- B  $30^\circ$
- C  $45^\circ$
- D  $90^\circ$



## SULIT

- 34 Given universal set  $\xi = P \cup Q \cup R$  such that  $P \subset R$ ,  $P \cap Q \neq \emptyset$  and  $Q \not\subset R$ .  
 Diberi set semesta  $\xi = P \cup Q \cup R$  dengan keadaan  $P \subset R$ ,  $P \cap Q \neq \emptyset$  dan  $Q \not\subset R$ .

Which of the following is the Venn Diagram for the relation of set P, set Q and set R?  
 Antara berikut, yang manakah gambar rajah Venn bagi menunjukkan hubungan set P, set Q dan set R?

A

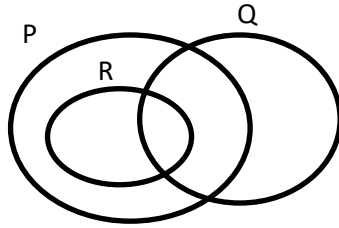

C

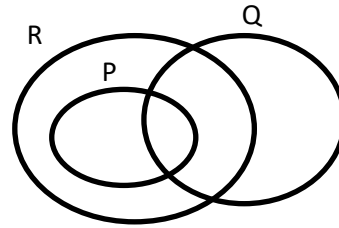

B

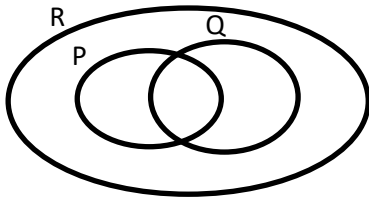

D

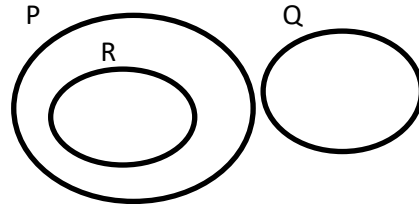

## SULIT

- 35 Diagram 15 is a Venn diagram showing the number of visitors in set  $\xi$ , set P and set R in a specific time. Table 1 shows the number of elements in each set.

*Rajah 15 ialah gambar rajah Venn menunjukkan bilangan pengunjung dalam set  $\xi$ , set P dan set R dalam suatu tempoh tertentu. Jadual 1 menunjukkan bilangan unsur dalam setiap set.*

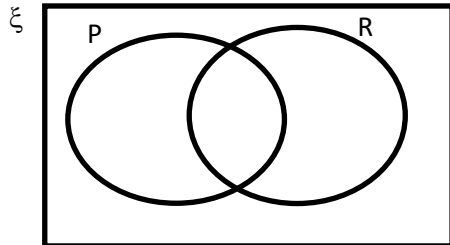

Diagram 15  
*Rajah 15*

Set	Number of elements
Universal set, $\xi$	250
Set P	124
Set R	106

Table 1  
*Jadual 1*

Given universal set  $\xi = \{\text{visitors of agricultural expo}\}$ , set P = {visitors of Bird park} and set R = {visitors of butterfly park}. The number of visitors who did not enter any of the parks is 50.

*Diberi set semesta  $\xi = \{\text{pengunjung ekspo pertanian}\}$ , set P = {pengunjung Taman Burung} dan set R = {pengunjung Taman Rama-Rama}. Bilangan pengunjung yang tidak memasuki mana-mana taman ialah 50.*

Admission fee to enter the agricultural expo is free but visitors have to pay RM5 to enter the Bird Park and RM6 to enter the Butterfly Park. For those who visit both parks, they only need to pay RM10.

Calculate the amount of payment collected by the organizer during the period.

*Tiket memasuki ekspo pertanian adalah percuma tetapi pengunjung perlu membayar RM5 untuk memasuki Taman Burung dan RM6 untuk memasuki Taman Rama-Rama. Bagi pengunjung yang melawat kedua-dua taman, mereka hanya perlu membayar RM10.*

*Hitung jumlah bayaran yang dikutip penganjur dalam tempoh tersebut.*

- A RM1 226
- B RM1 236
- C RM1 238
- D RM1 256

**SULIT**

- 36 Diagram 16 shows a straight lines PQ and RT. Both lines intersect at point T which lies on  $x$ -axis.

*Rajah 16 menunjukkan garis lurus PQ dan RT. Kedua-dua garis bersilang pada titik T yang terletak pada paksi-x.*

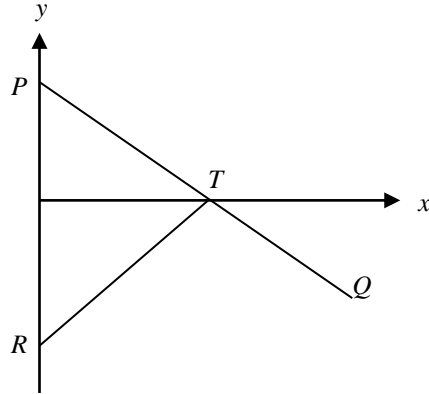

Diagram 16  
*Rajah 16*

Given equation of line RT is  $2x - y = 6$  and  $PT = 5$  unit. Calculate the gradient of PQ.  
*Diberi persamaan garis RT ialah  $2x - y = 6$  dan  $PT = 5$  unit. Hitung kecerunan PQ.*

- A  $-\frac{5}{2}$   
 B -2  
 C  $-\frac{4}{3}$   
 D -1

**SULIT**

- 37 There are 20 boys in Mathematics club. The probability of choosing a girl at random from the club is  $\frac{3}{5}$ . After holiday, 3 girls move in and become the member of the club. Calculate the number of girl members in Mathematics club now.

*Terdapat 20 murid lelaki dalam Kelab Matematik. Kebarangkalian memilih secara rawak seorang murid perempuan dari kelab itu ialah  $\frac{3}{5}$ . Selepas cuti, 3 murid perempuan telah berpindah masuk dan menjadi ahli kelab. Hitung bilangan ahli perempuan dalam kelab itu sekarang.*

- A 11
- B 15
- C 30
- D 33

- 38  $x$  varies directly as square of  $y$ . Given that  $x = 3$  when  $y = 4$ . Find the constant,  $k$  for the equation that relate  $x$  and  $y$ .

*$x$  berubah secara langsung dengan kuasa dua  $y$ . Diberi bahawa  $x = 3$  apabila  $y = 4$ . Cari pemalar,  $k$  bagi persamaan yang menghubungkan  $x$  dan  $y$ .*

- A 6
- B 2
- C  $\frac{3}{4}$
- D  $\frac{3}{16}$

**SULIT**

- 39 Diagram 17 shows a graph P versus  $\frac{1}{T^2}$ .  
*Rajah 17 menunjukkan graf P melawan  $\frac{1}{T^2}$ .*

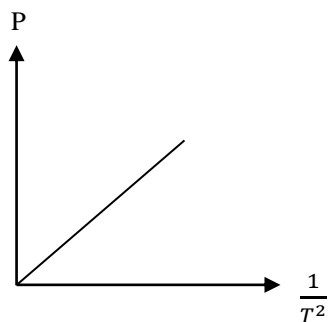

Diagram 17  
*Rajah 17*

Express P in term of T when P = 2 and T = 9.  
*Ungkapkan P dalam sebutan T apabila P = 2 dan T = 9.*

- A  $P = \frac{162}{T^2}$
- B  $P = \frac{2}{81}T^2$
- C  $P = \frac{6}{T^2}$
- D  $P = \frac{2}{3}T^2$

**SULIT**

40 Given  $\begin{pmatrix} 2 & -2 \\ -1 & 6 \end{pmatrix} \begin{pmatrix} x \\ x - y \end{pmatrix} = \begin{pmatrix} 4 \\ -1 \end{pmatrix} - \begin{pmatrix} y \\ -1 \end{pmatrix}$ , find the value of  $x$  and the value of  $y$ .

Diberi  $\begin{pmatrix} 2 & -2 \\ -1 & 6 \end{pmatrix} \begin{pmatrix} x \\ x - y \end{pmatrix} = \begin{pmatrix} 4 \\ -1 \end{pmatrix} - \begin{pmatrix} y \\ -1 \end{pmatrix}$ , cari nilai  $x$  dan nilai  $y$ .

	$x$	$y$
A	$\frac{12}{5}$	2
B	$\frac{8}{5}$	$\frac{4}{3}$
C	$\frac{4}{15}$	$\frac{4}{3}$
D	$\frac{2}{5}$	2

**INFORMATIONS FOR CANDIDATES  
MAKLUMAT UNTUK CALON**

**SULIT**

1. This question paper consists of **40** questions.

*Kertas soalan ini mengandungi 40 soalan.*

2. Answer **all** questions.

*Jawab semua soalan.*

3. Answer each question by blackening the correct space on the objective answer sheet.

*Jawab setiap soalan dengan menghitamkan ruangan yang betul pada kertas jawapan objektif.*

4. Blacken only **one** space for each question.

*Hitamkan satu ruangan sahaja bagi setiap soalan.*

5. If you wish to change your answer, erase the blackened mark that you have done. Then blacken the space for the new answer.

*Sekiranya anda hendak menukar jawapan, padamkan tanda yang telah dibuat. Kemudian hitamkan jawapan yang baru.*

6. The diagrams in the questions provided are not drawn to scale unless stated.

*Rajah yang mengiringi soalan tidak dilukis mengikut skala kecuali dinyatakan.*

7. A list of formulae is provided on pages 2 to 4.

*Satu senarai rumus disediakan di halaman 2 hingga 4.*

8. You may use a scientific calculator.

*Anda dibenarkan menggunakan kalkulator saintifik.*